

## EXPLORING WITH EUREKA

**Exploration just became easier, with the launch of the ground-breaking Maptek Eureka™ software.**

A powerful 3D visualisation and multi-processing platform enables interpretation of a wide range of geospatial data. High resolution imagery, seismic, gravity, magnetic and other geophysical survey data can be displayed in the same space as the drilling, allowing geologists to immerse themselves in the data and quickly come to a better understanding of their exploration projects.

Eureka manages large datasets with ease. No detail is lost while moving between different scales; users can see the big picture as well as analyse target areas in detail. Almost unlimited control is gained over drilling data, with interactive display and editing tools for drawing, georeferencing of imagery, drillhole editing, surface modelling, surface arithmetic, and contouring.

Eureka handles aerial photography, terrain maps, historical plans and GIS data. Importantly, Eureka can import and display SEG-Y format seismic data with a unique approach to visualise seismic reflectivity and amplitudes. A smart tracking tool helps in the interpretation of features of interest such as horizons or faults.

A velocity model can be applied to seismic sections, using the drillhole information to convert the seismic time data into depth. Detailed seismic data can then be incorporated into horizon models, providing additional information to correlate the models of the resource.

As well as drilling and geophysical data, Eureka accepts high resolution jpeg and ecw files and multi-attributed data. Numeric attributes can be assigned to the z coordinate, so attributes can be viewed in 3D. Additional attributes can be derived from data using inbuilt scripting tools.

Developing Eureka in collaboration with industry, Maptek prototyped an interactive field tablet for entering drillhole data via drop-down lists, handwriting recognition or virtual keyboard. Logged data can be

synchronised between the tablet and the Eureka desktop application in real time.

Maptek's innovation helps geologists apply their professional skills to reach the 'Eureka' moment, where all the pieces of the data puzzle come together to indicate the presence of a potentially economic mineral or energy resource.

Speaking at the official launch of Eureka 1.0 at the North America users conference in Denver, Maptek CEO Barry Henderson said that Maptek had developed Eureka to help explorers satisfy the massive global demand for minerals and energy.

'In the next 30-50 years, the world will consume as much copper as has been mined historically. The same applies to iron ore and other metals,' Henderson said.

Maptek will continue to develop the Eureka software to deliver tools that will benefit the resources industry. 

Email [eureka.sales@maptek.com.au](mailto:eureka.sales@maptek.com.au) for a demonstration of Eureka or visit [www.maptek.com/eureka](http://www.maptek.com/eureka) to learn more

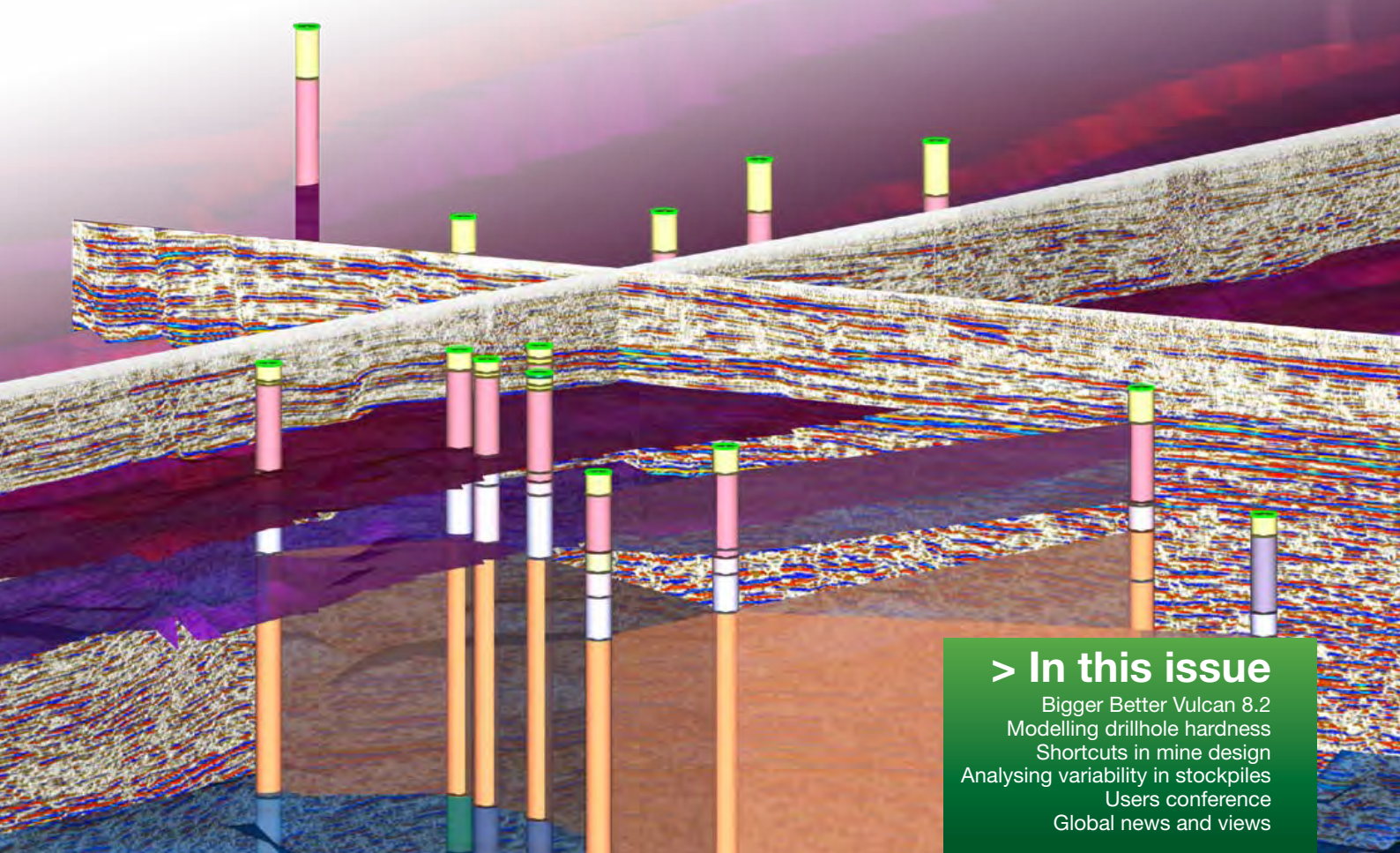

### > In this issue

- Bigger Better Vulcan 8.2
- Modelling drillhole hardness
- Shortcuts in mine design
- Analysing variability in stockpiles
- Users conference
- Global news and views



# BIGGER BETTER VULCAN 8.2

More than 70 'user stories' have been incorporated in Vulcan version 8.2 which was released in November.

The **Rapid Pit Design** tool aids users to quickly evaluate alternative pit scenarios. Multiple iterations can be projected from benches and strings. Ramps and switchbacks can be added as desired. HotKeys can be used to allocate benches as ore or waste, to double bench, to clip to topography, and to generate tonnage and grade within seconds.

The **CSV Import** tool builds a new Isis database from csv files without needing to design the database first. Users can also load an existing database and change the fields or tables on the fly to create a new database.

A new option under **Support Analysis** allows users to analyse data to determine ideal block size based on entered cut-off values, and evaluate an estimated model against existing data. Conceptual resource numbers can be obtained straight from a drillhole database without first generating complex block models.

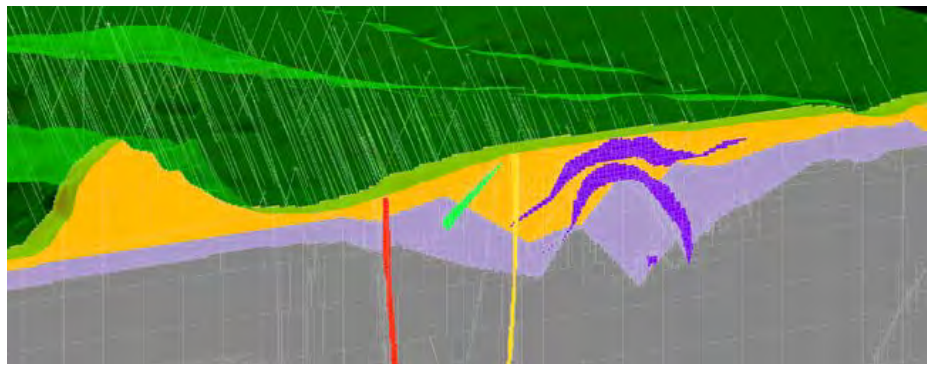
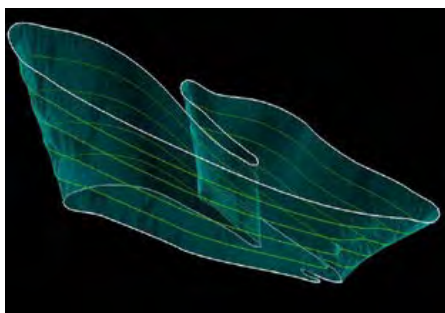

**Grade Estimation** now allows search distance and search orientation values to be stored as block model variables. Separate dip and dip direction can be considered in unfolding, resulting in a better representation of the orebody orientation. Orientations between surfaces can be calculated as bearing, plunge and dip. Search orientation vectors can be displayed on a block by block basis.

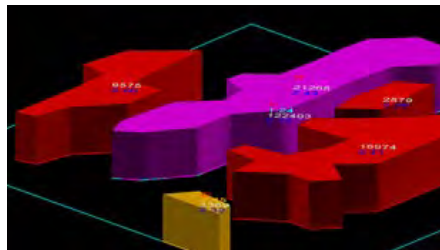

The **Triangulation Attributes** tool allows metadata to be stored within the triangulation data structure. Other users sharing the project can see all the data.

The **256 Colour** palette introduces a new colour selection and editing interface with more predefined colour gradients. New design databases will be automatically created in the extended format and will also work in 32 colour mode.

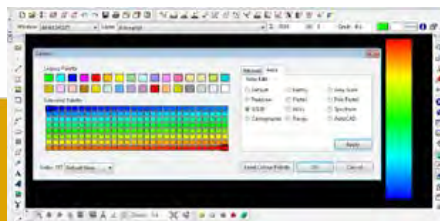

**Polygon Morph** interpolates polygon shapes between existing polygons, creating smoother transitions between digitised shapes. The new attribute editor can be used to store information such as volume or date created.

The new **Polygon Flag** option provides additional flexibility in assigning parameters within a block model both before and after grade estimation. The flagged attributes are carried through the triangulated model and into the grade shell.

The **Attribute Editor** allows users to assign and manipulate attributes of design objects at the same time. Attributes are easily copied from one design object to another, and Perl scripting can be used to change items in the group in one pass.

**Chronos** performance is enhanced by moving scheduling calculations to Excel where the data is located.

More robust **Boolean** operations ensure reliability for intersecting triangulations, building and manipulating solids.

New options under **Variography** display the variance sill and fit variography solely to a major direction. Other changes include support for **ecw** and **jpeg2000** formats in Vulcan 64-bit.

Maptek Vulcan™ 8.2 is the second release in **64-bit**. The installer includes support for patching, ensuring users keep up-to-date with the latest improvements. Customer beta testing and rigorous internal quality assurance have resulted in a robust release which also delivers a great user experience.

# MODELLING DRILLHOLE HARDNESS TO ENHANCE BLAST DESIGN

**Introducing Maptek BlastLogic™ into the existing mine systems mix makes for a new industry standard in drill and blast management.**

Advances in drill rig guidance and management systems allow mines to profile hardness and downhole penetration rates and use this data to improve their blast design. For example, identifying a band of hard rock across specific regions of a shot means an engineer can customise hole-by-hole explosive load design to achieve optimal fragmentation.

Harnessing the value of this relies on the interdependency of mine planning, drill management and the load design systems used by drill & blast. Maptek Vulcan™ and BlastLogic software can be used with site drill navigation systems to provide a straightforward solution for routine mine operations.

The drill design is performed in Vulcan, and passed to drill navigation which in turn delivers back the hardness data. Vulcan displays the hardness profile of each hole by colour. A hardness horizon can then be tracked to form a surface model. In a coal mine, the roof and floor surfaces of seams are modelled.

BlastLogic is used to validate and update the correct spatial location and dimensions of each drillhole, coordinate the QA process and prepare the load design, all at a click of a button.

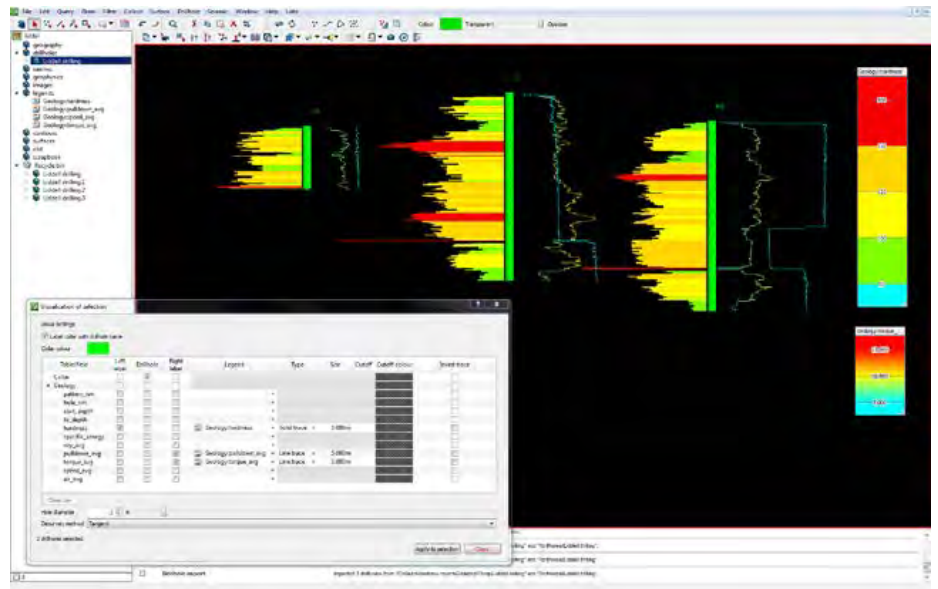

Colour legend profiling drillhole hardness (Eureka)

The Vulcan to BlastLogic workflow is seamless, with common datasets allowing click-drag-drop functionality. BlastLogic also supports an automated interface with the major drill navigation systems; this allows as-drilled data to be accessed and viewed immediately.

BlastLogic charge design functionality will soon support deck loading off a surface. This solution will meet the needs of coal mines relying on through-seam blasting, as well as hard rock mines wanting to discriminate on the hole-by-hole load design, given degrees of hardness within the shot.

This helps minimise waste as the optimal amount of explosive charge can be applied per hole. It also maintains toe and wall control and eliminates the expensive overhead of handling oversize rock.

Another high-value deliverable is the facilitation of accurate placement of charge, which historically has been difficult to track and measure.

BlastLogic supports the visualisation and use of dxf files for operations with third-party mine planning and geological modelling systems.

Another solution involves bundling the new exploration modelling software, Maptek Eureka™ with BlastLogic. The same effortless workflow creates drillhole hardness profiles and surfaces that can be used in BlastLogic to enhance a blast design.

This is one example of how Maptek can help mines better manage the optimum recovery of ore and coal so as to achieve quantum savings. 

Email [blastlogic@maptek.com.au](mailto:blastlogic@maptek.com.au) for more information on BlastLogic

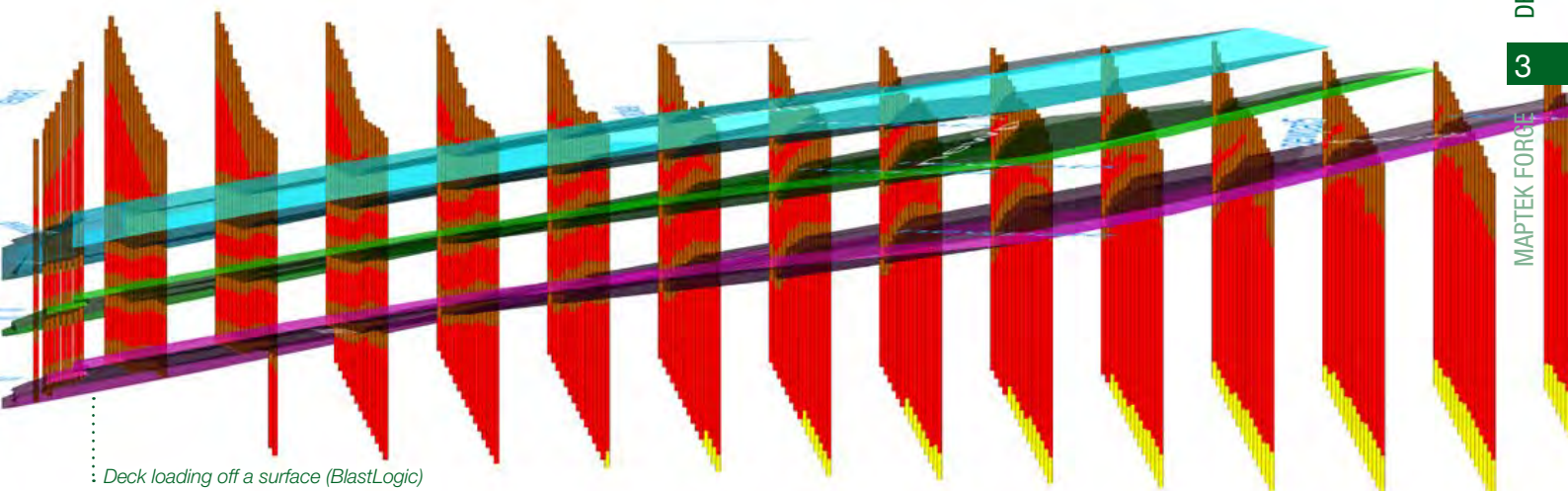

Deck loading off a surface (BlastLogic)



# SHORTCUTS IN MINE DESIGN

**Hongliang Wang, Mining Optimization Engineer of Newmont Mining Corporation, initiated a shortcut for evaluating alternate underground designs.**

Wang was tasked with developing a full-scale mine design for an underground project at Nevada's Carlin Gold Trend.

'Underground precious metal mining is difficult,' said Wang. 'Manual stope design is time consuming and error prone.'

Underground mine design automation and optimisation is a complex task. Generating 3 to 6 scenarios for a proper comparison and sensitivity analysis at different metal prices and cut-off grades can take months.

Traditional methods required more than 3 weeks to complete 1 mine-wide detailed design. When management requested another 16 options for

evaluation, new methods had to be explored in order to meet the schedule for bringing the site into production.

After thousands of stope designs were made, point by point, line by line, and ring by ring, Wang discovered an incremental-analysis-based stope design and cutoff grade calculation method (3D-IASD).

'The traditional methods did not allow for a logical or spatial relationship between rings,' he said. 'I realised proper naming could save a significant amount of time.'

Mining shapes, such as cut-and-fill drifts and stopes, are typically manually drawn by engineers, based on the block model

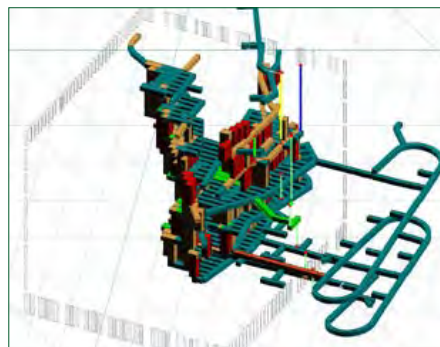

and cut-off grade. The new method can replace manual checking and provide a final stope shape with maximum values.

**The 3D-IASD method significantly reduced errors and provided accurate cut-off grade calculations, saving time.**

The five step process involves: 3D grid setup; filtering out rings that do not contain grades; running the stope rings reserve report; building mineable stope shapes with various cut-off grades; and designing mine-wide stopes and development.

According to Wang, Maptek Vulcan™ allowed Newmont to be creative when doing design work.

'Vulcan definitely made the process a lot easier. Simple but key tools such as 'multiple transfer' and 'auto naming' facilitated 3D setup; 'triangulation by polygon' and 'carry naming attributes' streamlined modelling; and the 'advanced reserve editor' gave us the results we needed,' he concluded. 

*Thanks to Hongliang Wang  
Mining Optimization Engineer/Scientist  
Newmont Mining Corporation  
Presented at 2012 North America Users Conference*

# ANALYSING VARIABILITY

**Cliffs Michigan Operations (CMO) found that using Maptek I-Site™ for survey significantly decreased variation in volume calculations of bulk material stockpiles.**

CMO Tilden and Empire mines regularly measure stockpiles of concentrate, pellets, flux stone and other materials. These surveys provide assessments of production and inventories for accounting; however patterns showed variation - both in excess and deficiency.

'By understanding the sources and magnitude of variation in the process, we can better manage our reconciliation,' said Kurt Peterson, CMO Manager of Training and Development, and project leader.

A 'repeatability and reproducibility' analysis was conducted to define the variability of the current surveying process. Two CMO surveyors performed multiple volume measurements of a single stockpile using GPS, collecting points from the base, middle and top.

The final 3D model of the stockpile contained triangular surfaces that 'averaged out' fine details. Outcomes varied with the number of points taken - more points creates a better model but requires longer cycle times.

In June 2011, CMO brought in I-Site, which is used at other Cliffs operations, to determine if this laser scanning process would provide a reduced level of uncertainty, and if there was a business case for transitioning to I-Site technology.

Mike Foster, Maptek I-Site Senior Technical Consultant, surveyed the stockpile from a tripod setup at multiple points. He then provided a volume calculation using a common base surface to capture the same volume between two scans of the pile.

**Comparison with CMO manual data showed a 70% improvement in measurement system variability when using I-Site.**

'Using the Six Sigma MSA methodology to design the study, and with Maptek help, we accomplished what had never been done before, establishing real life characterisation of the variation associated with such lidar measurement systems,' said Peterson.

CMO determined that the more peaks, valleys, ridges, and crests the stockpile had, the more time it took to walk the piles and make sure the detail was accurate. It also introduced a safety risk for the surveyor. The I-Site process greatly minimised time spent surveying the stockpile and decreased safety risks.

CMO noted additional benefits of the I-Site system, such as a 360° high definition photo of the area, compatibility with Vulcan and AutoCAD, the ability to measure from distances of 1500 metres, and vehicle mount capability. 

*Thanks to Kurt Peterson  
Manager of Training and Development  
Cliffs Michigan Operations  
Presented at 2012 North America  
Users Conference*

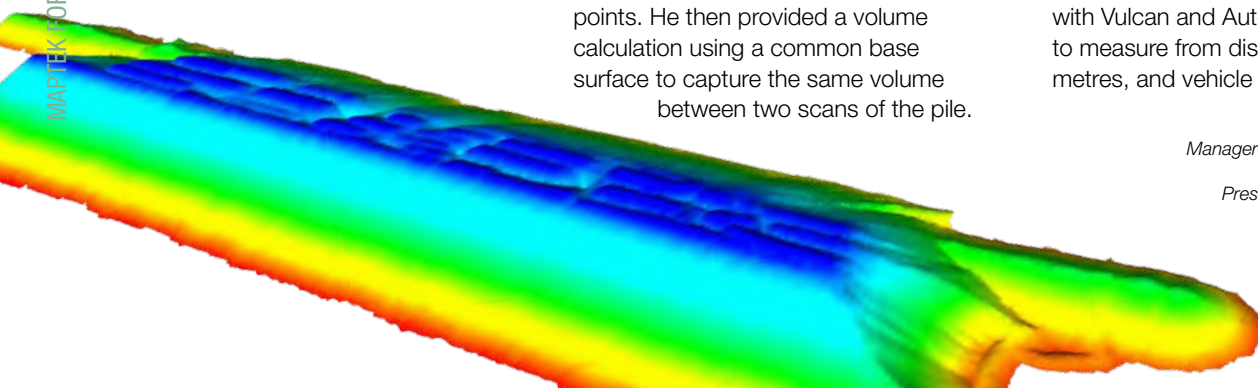

# MISSION ACCOMPLISHED

**The Denver office is coming back to earth after a fantastic Users Conference which saw 65 customers attend from across North America.**

Proceedings blasted off with a Keynote Address from astronaut and author, Colonel Mike Mullane. His 'Countdown to Safety' presentation provided relevant and actionable steps to maintain safety in the workplace.



Colonel Mike Mullane talks to attendees

Commenting on the overall calibre of the presentations, North American General Manager, Jon Larson said, 'The technical program was diverse and informative.'

'We heard how Vulcan is applied to design freeze walls for uranium mining through to how I-Site Studio is used to model landfill.'



Vulcan technical sessions covered improving stope measurements, coal washability, unfolding and underground mine design optimisation. I-Site topics included volumetrics, geotechnical mapping and stockpile reconciliation. Maptek Chief Software Engineer, Andrew Myers officially launched Eureka, and Blast Accuracy Solutions Manager, Mark Roberts introduced the benefits of BlastLogic for drill and blast operations.

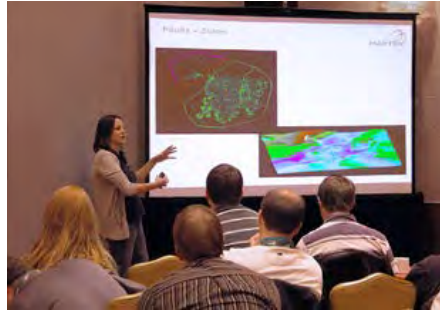

Attendees heard some novel applications for Vulcan software. Two students from Idaho State University are modelling structural controls on geothermal resources in Idaho, and Shannon Kobs Nawotniak explained how she uses Vulcan to model volcanic ash clouds.



Vulcan workshops and an I-Site forum on the final day provided an opportunity to learn new skills, hear about the latest tools and gain hands-on experience.

Networking started with welcome drinks on Tuesday night. At Wednesday's conference dinner, three people were honoured for their 25 year connection with Maptek. Thursday night gave attendees a chance to unwind and play some pool at the Wynkoop Brewery.

## 25 YEARS AGO

**Software engineers Andrew Myers and Bill Blattner started at Maptek within months of each other in 1987.**

Andrew joined the Sydney office and Bill became the third member of the Denver team. While neither writes as much code as they used to, their work forms the basis for much of the functionality across Vulcan today. Andrew has also written code for I-Site, BlastLogic and Eureka.



Bill Blattner, Marc Silverman and Andrew Myers with Maptek CEO Barry Henderson

Marc Silverman put Andrew and Bill's work to the test as one of the first Vulcan customers in North America. Peabody Energy bought Vulcan in 1987 with Marc helping with site installation.

After a few false starts and new data tapes shipped from Australia, Peabody was up and running. Marc still uses Vulcan today and his input has been valuable in Vulcan development.





# SOUTH AFRICA

The University of the Western Cape (UWC) in South Africa will introduce Vulcan to more than 500 students in its Department of Earth Sciences.

The Geology and Environmental Sciences group is at the forefront of visual and interactive teaching methods, and established a Highly Immersive Visualisation Environment (HIVE) in 2010.

The acquisition of Vulcan in July 2012 continues their tradition of applying 3D visualisation of geological and mining datasets to enhance data interpretation. This initiative, the largest single installation of Vulcan in Africa, aims to better equip a future generation of geoscientists.

The UWC vision includes making Vulcan available across all areas of research and to enhance the scope of postgraduate ventures, especially in Economic Geology.



Paul Ehlers and Duncan Lee (Maptek) with Professor Charles Okujeni, Head of Department of Earth Sciences at the University of Western Cape

The use of Vulcan will help broaden the scope of research within the Earth Science Department to include more sophisticated economic, mining and exploration modelling methods.

The Department also plans to incorporate Vulcan into a second year course as an introduction to geological modelling techniques.

'Vulcan will enhance the research capabilities and skills development of students. Maptek and UWC will leave behind a lasting legacy through technological innovation,' said Paul Ehlers, Technical Services Manager, Africa.

# VULCAN IN ASIA

Maptek has appointed new Vulcan resellers in Mongolia and India.

Staff from Adelaide, Perth, Sydney and Denver offices have been travelling to Mongolia to roll out Vulcan and train users.

'The initiative will deliver improved support and supplier interaction where it's needed,' said Maptek General Manager Australasia and the Pacific, Peter Johnson.



Maptek booth at Mining Mongolia in September

'While our staff are experienced in training at remote sites, our new relationship with Information Technology Experts LLC in Mongolia will deliver better response times, closer day-to-day interaction and local language support to our customers in Mongolia,' he explained.

The Mongolian miners see themselves as innovators in mining technology, which is a good fit with Maptek.

India is another region where miners are demanding better technical capability to meet demands in the local industry.

'India has a wealth of natural resources and significant areas yet to be fully explored,' Johnson said. 'The agreement with Sumeru Cooe Pte Ltd will set up a strong team delivering the best technology solutions and outstanding local support to mining companies across India to help optimise their operations.'

'Maptek has the best products, and we are committed to delivering the best technical support and services for our customers in all regions,' concluded Johnson.

Mining Engineering alumni from the University of La Serena with Leonardo Larenas, Andrés Díaz, Juan Rivera and Gastón del Valle (Maptek)

# EUROPE

Staff from Edinburgh office are showcasing Maptek products to a wider audience in Europe.

Callum Dowds, Technical Sales Consultant for I-Site, attended SPAR Europe in The Hague, Netherlands in November. The 3D-based event was packed with innovators from all over Europe. Callum showed off Maptek developments in I-Site hardware and I-Site Studio software.

Gary Buchanan will be at Europe's leading mining investment event in December at Mines and Money London. Callum and Gary will demonstrate the range of Maptek products, including data from our new release, Eureka, at Booth H16.



Callum Dowds at SPAR Europe in November

Maptek is Gold Sponsor for December's European Lidar Mapping Forum in Salzburg. Graeme Cowie, I-Site Manager Europe, will present mining applications of laser scanning. Visit Maptek at Stand 62.

# SIDMMA CHILE

Maptek was gold sponsor at the 2nd Seminario de Innovación y Desarrollo Minero Medio Ambiental in Chile.

Held at the Department of Mining Engineering of the University of La Serena, the event promotes transfer of knowledge through discussion and analysis of technological innovations and recent developments in the mining world.



## USERS AREA

Maptek is launching a new online customer portal in January 2013.

Customers can track and manage their own support cases, search a knowledge base of FAQs, solutions and 'how-to' videos, and learn from tips and tricks.

A forum will also be launched, for Vulcan users to share information online. Users can draw from a repository of more than 400 solution articles. Vulcan downloads will also be accessible.

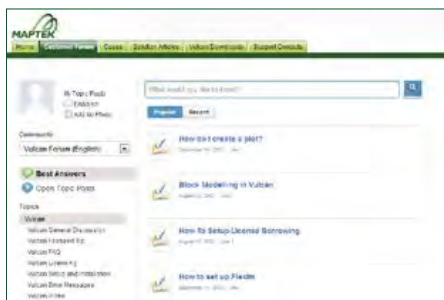

'We want customers to be able to easily access information,' said Stewart Maurer, Director of Global Marketing.

'The portal is something customers have asked for. It will be an essential tool in the Maptek customer service matrix.'

All Vulcan users with current maintenance will be able to access the users area at no extra cost. Information about creating accounts will be sent by email early in the new year, along with a secure login.

Attendees at the North America Users Conference had a preview in October. In 2013 access will be extended to users of I-Site products, with BlastLogic and Eureka to follow.

## EXPOMINA PERU

Expomina is one of the biggest mining tradeshows in South America.

Maptek representatives from Chile and Peru attended the event in September.



Alvaro Quezada (Chile) and Luis Castillo (Peru)

## LAOS TRAINING

Maptek is rolling out Vulcan and conducting training at MMG Sepon in southern Laos.

The open cut copper and gold mine, which is operated by Lane Xang Minerals Limited (LXML), will use Vulcan for geology, mine planning, drill and blast, geotechnical, hydrology and surveying.



Technical services and sales staff from several Australasian Maptek offices have visited Sepon to train site staff in using Vulcan

Minmetals Resources Limited owns 90% of LXML, while the Lao Government owns the other 10%. Lane Xang is Lao for 'one million elephants', an historical name for the kingdom of Laos.

## RIDE 4 CANCER

Thousands of bikes, 4 states and 1 common goal - Maptek cyclists and supporters joined the recent Australian Ride to Conquer Cancer.

Riding more than 200 km over 2 days in Brisbane, Sydney, Perth and Melbourne, the Maptek teams gave our cycling jerseys an airing for a great cause.



The start in Sydney, NSW (above)  
On the road south of Perth, WA (below)



## I-SITE IN CHINA

Maptek I-Site technology will be more widely available in China thanks to a new agreement with Beijing STS Instrument Co Ltd.

The National Expo for Surveying and Geomatics Equipment, in Xi'an, Shaanxi province, and the China Mining 2012 Conference and Exhibition in Tianjin, provided the first opportunities for visitors to see the new I-Site 8810 scanner.

Beijing STS staff received training in the applications and benefits of the latest long range scanning technology from Maptek.



- 01 James Moncrieff, Maptek with STS CEO Frank Wang and Deputy GM David Wang
- 02 I-Site 8810 attracts a crowd at China Mining
- 03 Technical sales team at the National Expo for Surveying and Geomatics Equipment
- 04 I-Site 8810 in action at a coal mine in China



## BLASTLOGIC

**WESFARMERS CURRAGH** metallurgical coal mine in Queensland's Bowen Basin has acquired BlastLogic. The new drill & blast solution will improve the collation of as-drilled metrics to assist optimisation of drilling resources, and ensure the accurate placement of charge to minimise coal loss and dilution.

## VULCAN

**CALDERA MINERAL SERVICES**, based in Hollywood, California, is leasing Vulcan for geology work at its underground gold operation - **CAMP BIRD MINE** in Ouray, Colorado.

**CEMENTOS MOCTEZUMA**, a company in Morelos State, Mexico, dedicated to the production and sale of cement, will use Vulcan for mine planning and modelling.



Jorge Sanchez (Maptek) at Cementos Moctezuma

**CHINA GOLD INTERNATIONAL RESOURCES CORPORATION LTD**, based in Vancouver, BC, Canada, has purchased Vulcan for mine planning of two gold operations.

**ENDEAVOUR SILVER CORP - EL CUBO MINE**, an underground silver operation in Guanajuato State, Mexico, will use Vulcan for resources modelling and mine planning.



Jorge Sanchez with staff from Endeavour El Cubo



**KOREA COAL CORPORATION** will use Vulcan for geological modelling, open cut and underground mine design, pit optimisation and mine scheduling at their coal operations in Indonesia.

**LXML** Sepon, Laos has purchased 17 Vulcan software licences for geology, mine planning, drill and blast, geotechnical, hydrology and surveying at their open cut copper and gold operations.

**MOROBE MINING - WAFI GOLPU JV** in Papua New Guinea will use Vulcan for geological modelling, geostatistical analysis and simulation for ore resource estimation and reporting at their large copper discovery.

**ROY HILL IRON ORE** has purchased multiple Vulcan licences for open cut mine design and mine planning in the development of a new iron ore project in Western Australia.

## I-SITE

**FIRMATEK 3D MAPPING SOLUTIONS, LLC** has purchased a fourth I-Site Studio licence to process lidar data from its service provider business in Selma, Texas.

**NEWMONT - BODDINGTON GOLD MINE** has acquired an I-Site 8800 system to improve the speed, accuracy and safety on current laser scanning applications of stockpiles, dam and end-of-month reconciliation. The I-Site Studio geotechnical module will be used to extract and analyse geotechnical information from the pit walls.

**TECK COAL LIMITED** has purchased the I-Site 8800 laser scanning system and I-Site Studio software for its Quintette operation in Tumbler Ridge, British Columbia. This is the seventh scanner Teck has purchased for Canadian operations.

**TROPICANA GOLD PROJECT**, a joint venture between AngloGold Ashanti Australia Ltd and Independence Group NL, will use the I-Site 8800 laser scanner and vehicle mount for pit updates, volumes, geological mapping and geotechnical analysis. The mine is 330 km northeast of Kalgoorlie on the edge of the Great Victoria Desert in Western Australia.

  
**MAPTEK**  
[www.maptek.com](http://www.maptek.com)



Maptek at Seminario Internacional de Minería, Hermosillo, Sonora, Mexico in October

## VISIT MAPTEK AT THESE TRADESHOWS IN 2013

### January 28-29

AME BC Mineral Exploration Roundup  
Vancouver, BC - Booth C15

### February 4-7

Indaba  
Cape Town, South Africa

### February 24-27

SME (Society of Mining Engineers)  
Denver, Colorado - Booth 1010

### March 3-6

PDAC Prospectors & Developers Forum  
Toronto, Ontario - Booth 1039

### April 15-18

SPAR International  
Colorado Springs, Colorado

### May 5-8

CIM (Canadian Institute of Mining)  
Toronto, Ontario - Booth 711

### June 6-7

Elko Mining Expo  
Elko, Nevada - Booth 110

### October 16-19

30 Convención Internacional de Minería  
Mundo Imperial  
Acapulco, Mexico - Stands 3051 & 3093

### November 3-8

APCOM  
Porto Alegre, Brazil



Maptek at Atexpo, Copiapó, Chile in November

Maptek Forge newsletter is published quarterly. You can receive it by mail, emailed pdf or emailed link to the Maptek website. Email [forge@maptek.com](mailto:forge@maptek.com) to subscribe or advise changes to contact details.

Articles may be reproduced with acknowledgement.

© 2012 Maptek

Maptek, Vulcan, I-Site, BlastLogic and the stylised Maptek M are registered and unregistered trademarks of Maptek Pty Ltd; Maptek Computación Chile Ltda; Maptek Computación Chile Ltda, Sucursal Perú; Maptek S de RL de CV; Maptek Informática do Brasil Ltda; and KRJA Systems, Inc. Marks are registered in one or more of the following countries: Australia, Brazil, Canada, China, Chile, Greece, India, Indonesia, Mexico, Perú, Republic of South Africa, Russia, Spain, UK & USA.